

CW-WZ-0104

4G External Antenna

Key Features

Frequency: 698-960MHz/1710-2700MHz

SMA Male Connector

Screw Mount

Dimensions 80*15mm



1. Antenna Electrical Characteristics

Band (MHz)	
Frequency (MHz)	698-960MHz/1710-2700MHz
VSWR	3.5/2
Efficiency (%)	61.56%/58.48%
Peak Gain (dBi)	4.35/3.98
Impedance (Ohm)	50
Polarisation	Vertical
Max. Input Power (W)	10
Connector Type	SMA Male

2. Material and environmental characteristics

inner structure	PCB
Material of Plastic	ABS
Cable Type	RG174
Connector Type	SMA Male
Dimensions (mm)	80*15MM
Antenna color	Black
Operation Temperature	-40 to +80
Storage Temperature	-40 to +80
Antenna Storage life(year)	10
Substance Compliance	ROHS

REV	Date	Description
X1	2022/12/28	New issue

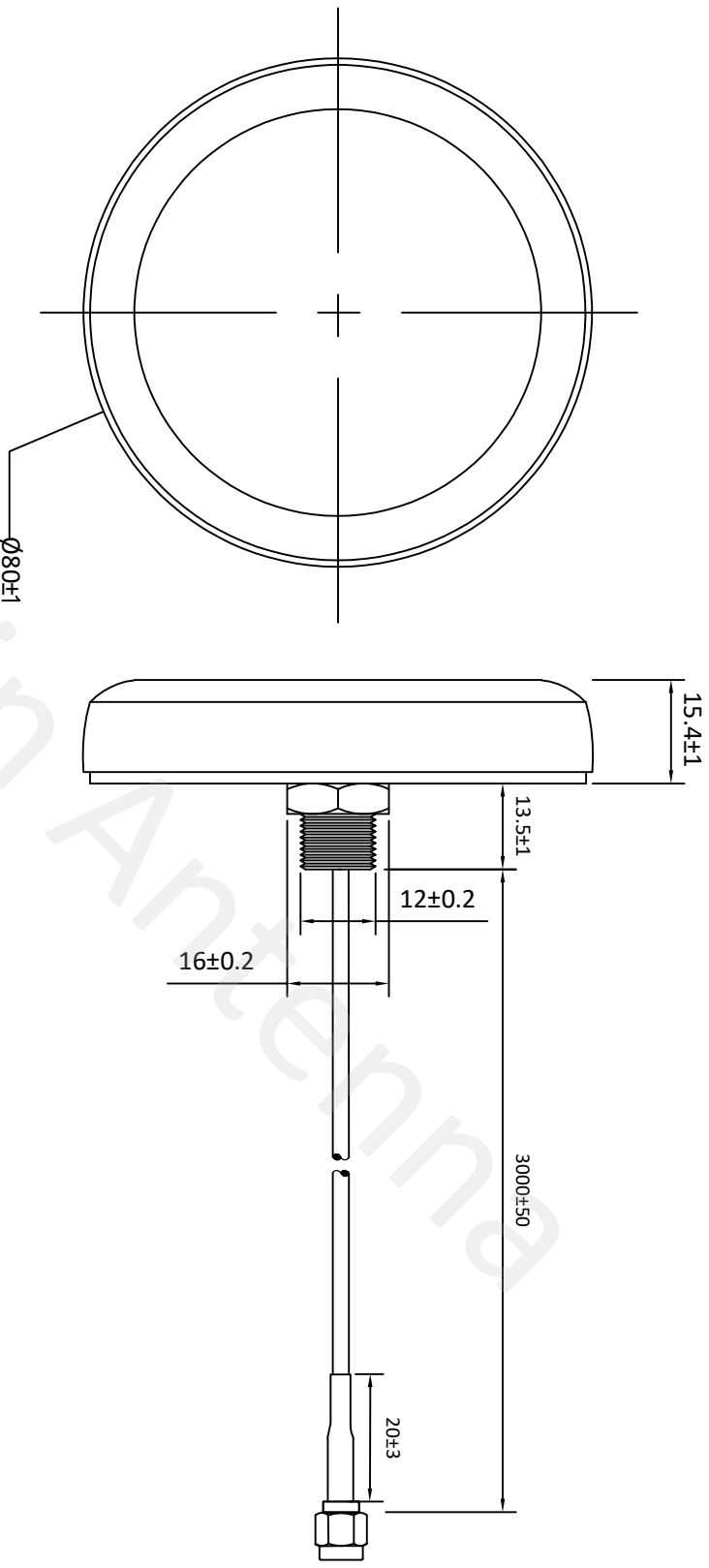

Specification(Free Test):
 Frequency Range: 698-960MHZ/1710-2700MHZ
 Impedance: 50Ω
 V.S.W.R: ≤3.5/2
 100% Continuity,short and open circuit test
 Materials, parts and process must by environmentally (ROHS)

7	Foam rubber	79*1MM	1	
6	Stud	Nickel plated brass	1	
5	Lower cover	Black ABS	1	
4	Shell	Black ABS	1	
3	Cable	RG174	1	
2	PCB	FR4	1	
1	Connector	SMA male	1	
NO	Name	Description	Q'TY	Remark
XX	±5.0	Approved		
X	±3.0			
.X	±1.0	Checked		
.XX	±0.2			
.XXX	±0.1	Drawing		
		Customer		
		Part NO.		
		Part name	External antenna	
		CW P/NO.	CW-ZH-0104	
		REV	X1	
		Unit	m/m	
		File		
		Sheet	1/1	



4. Antenna test parameters

Antenna Measurement Conditions:

Mounted on Ground Plane of 280 x 80 mm

Measured in Certified 3D Anechoic Chamber

The network analyzer is Agilent 5071c

The comprehensive tester is Agilent cmv500

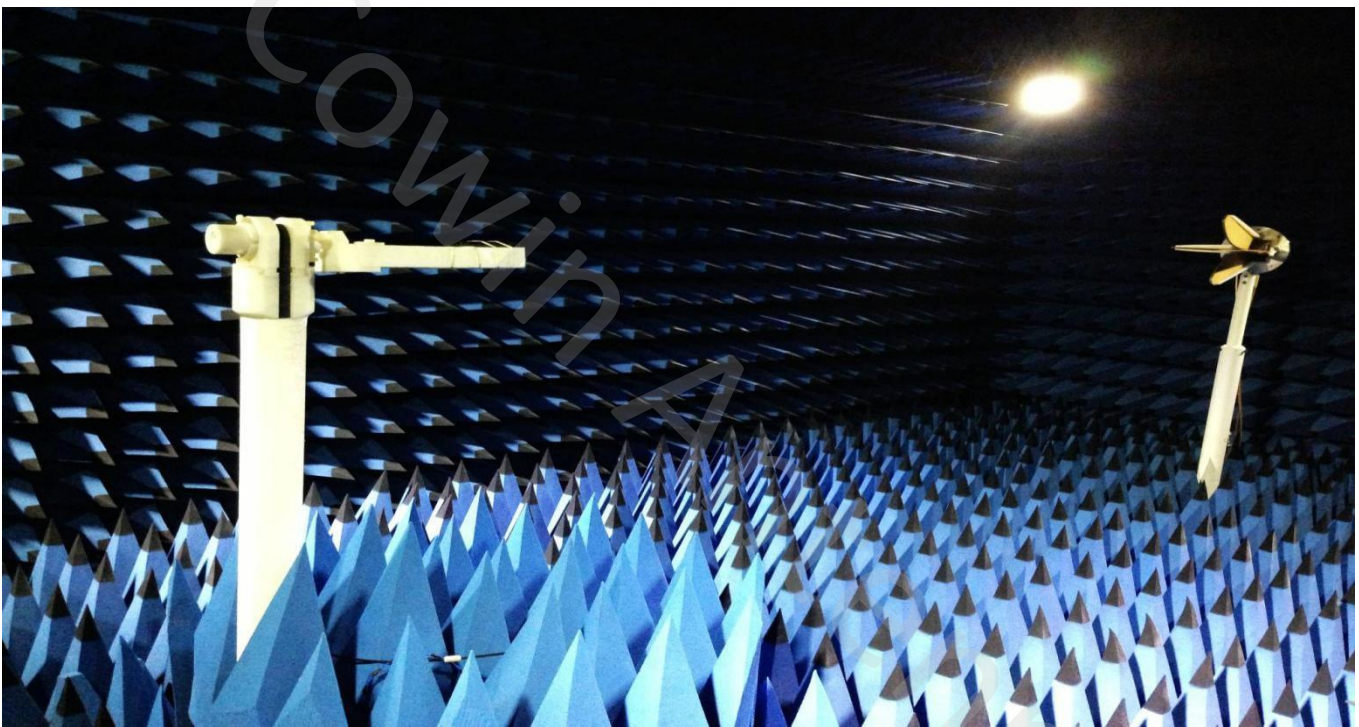

4.1 VSWR

Trc1 S11 SWR 1U/ Ref1U Cal



1

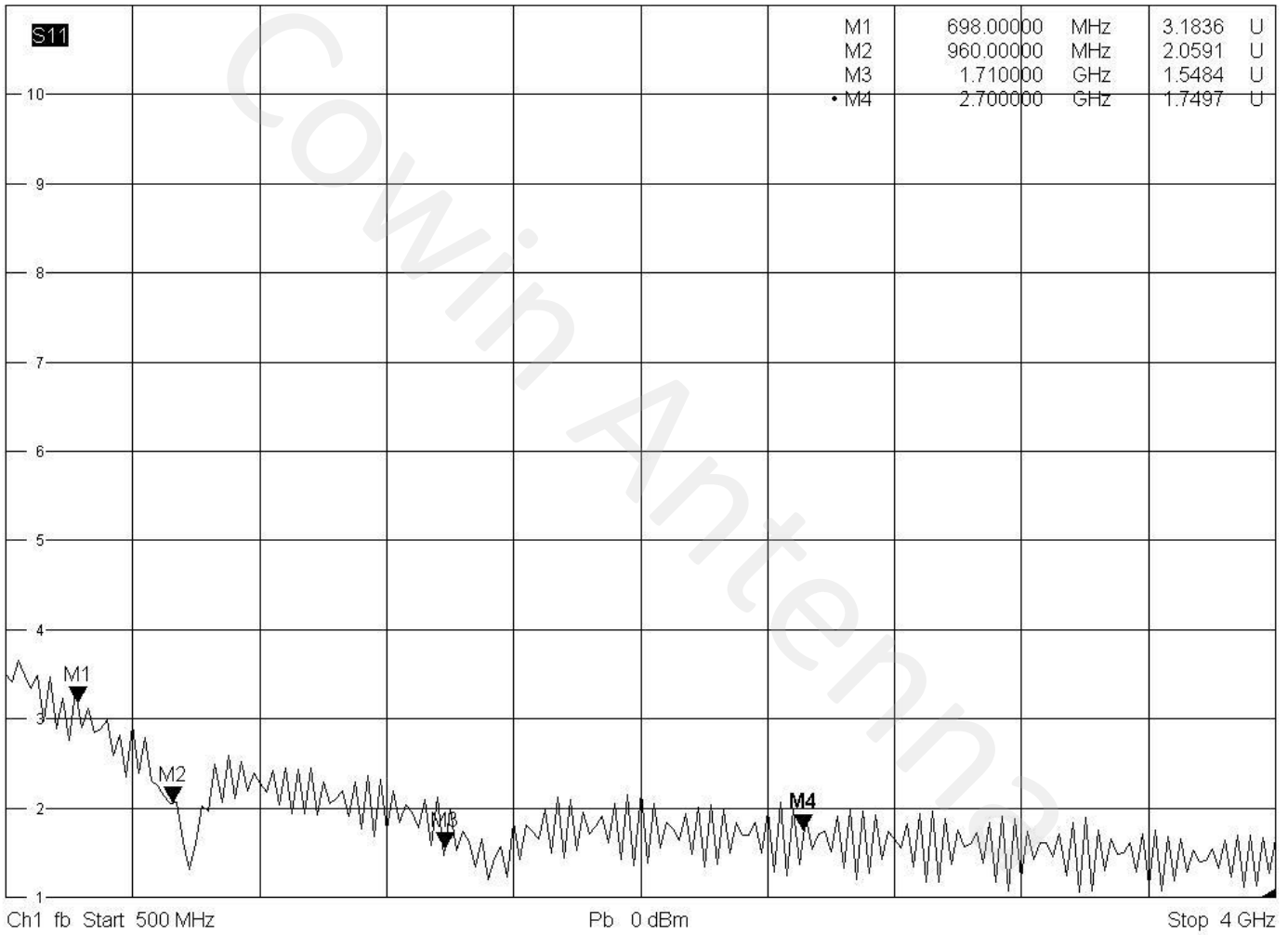

12/27/2022, 8:30 PM

4.2 Efficiency

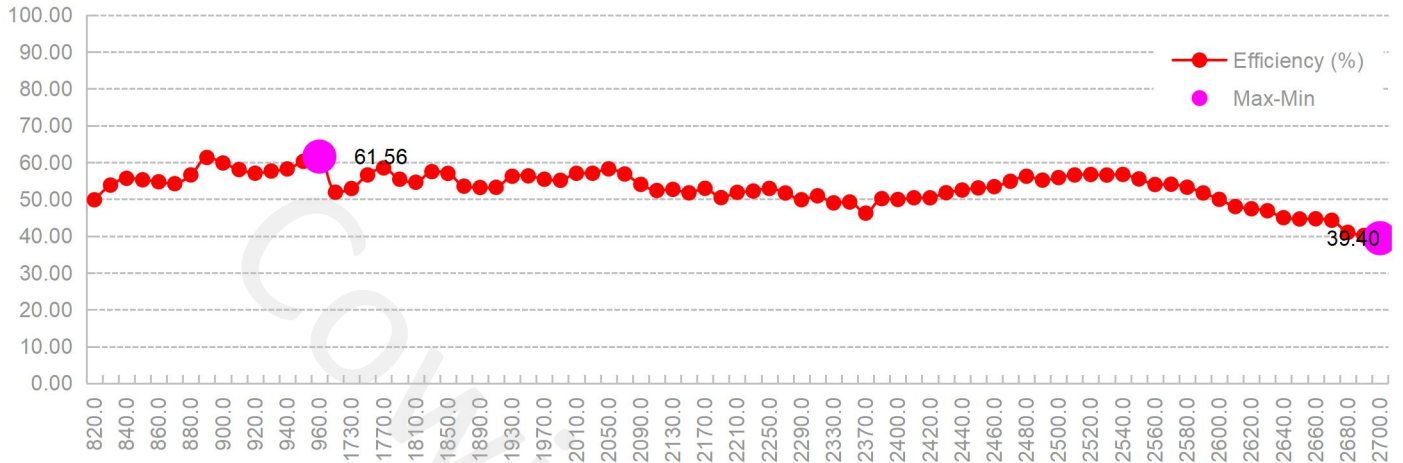

4.3 Peak gain

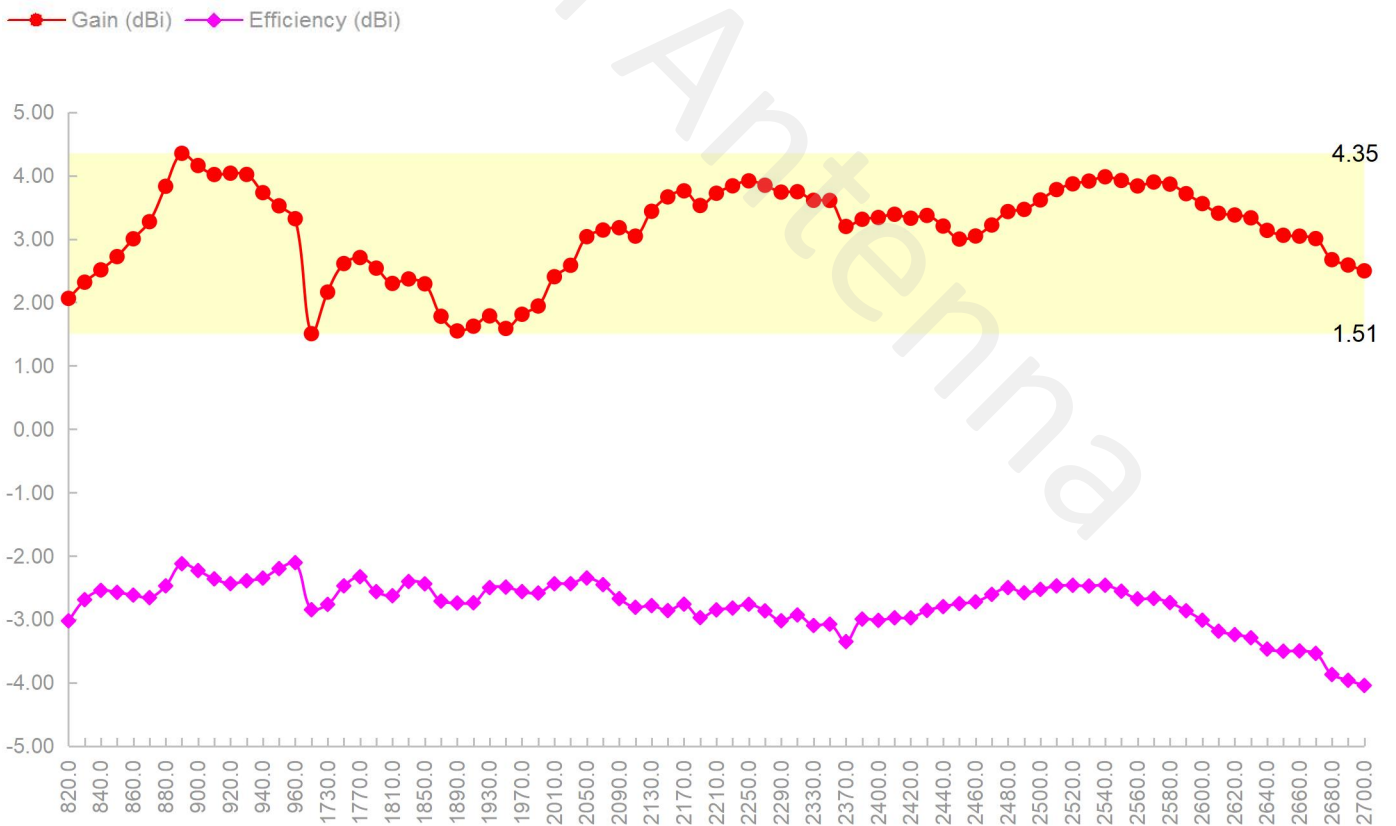

4.4 3D&2D Radiation Patterns

820.0MHz H+V, Eff: 49.8%



Back View

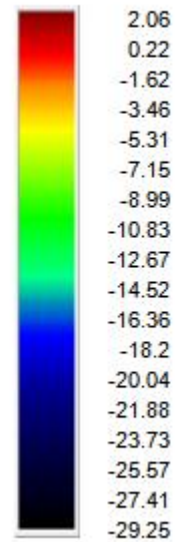
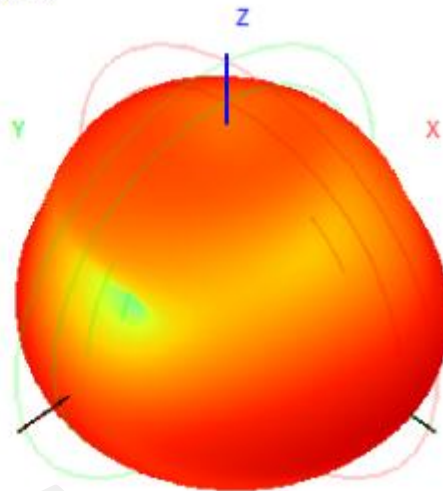

820.0MHz Total(E1-XZ), Max= 0.95dBi

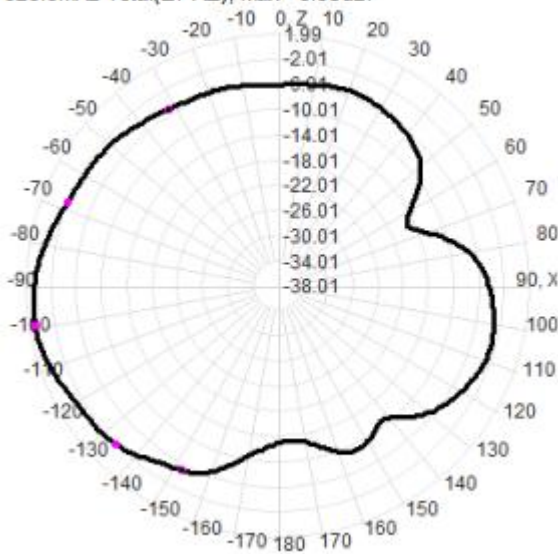

820.0MHz Total(E2-YZ), Max= 0.87dBi

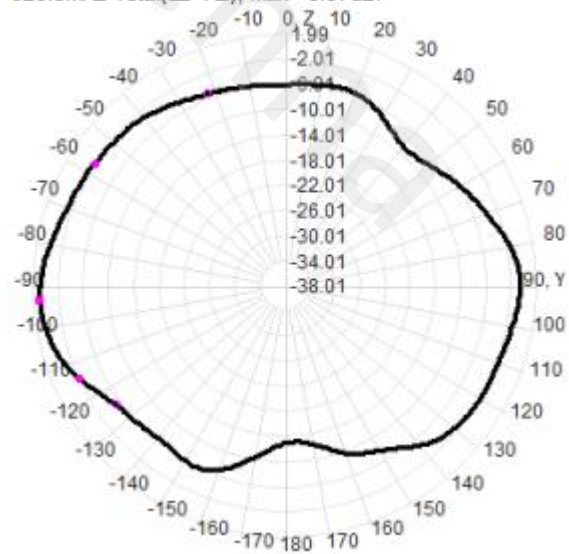

880.0MHz H+V, Eff: 56.6%

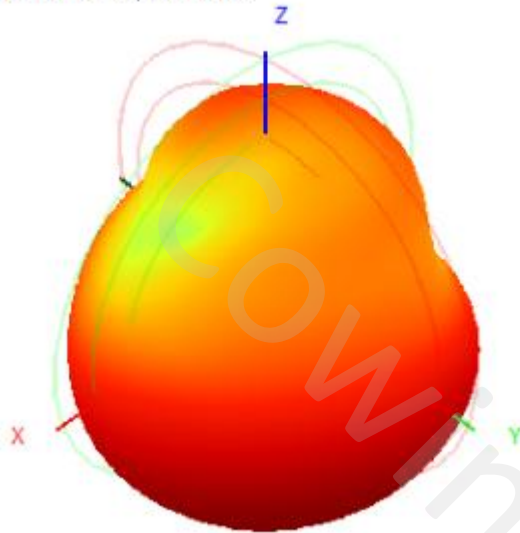

Back View

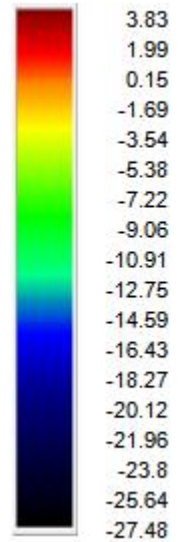
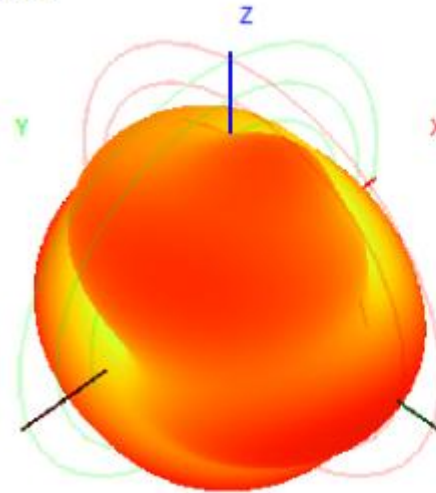

880.0MHz Total(E1-XZ), Max= 1.86dBi

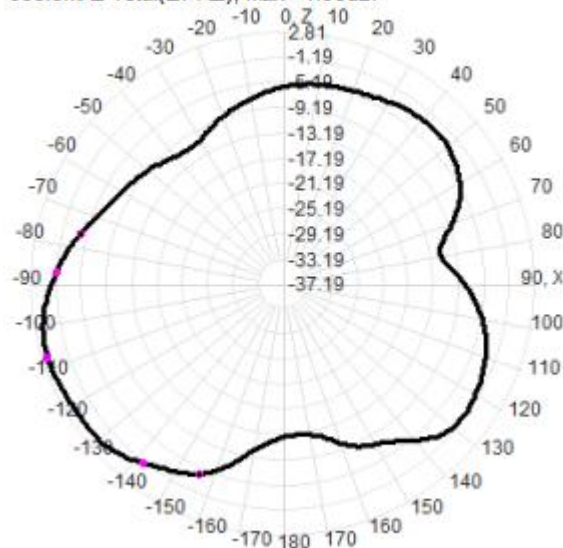

880.0MHz Total(E2-YZ), Max= 2.49dBi

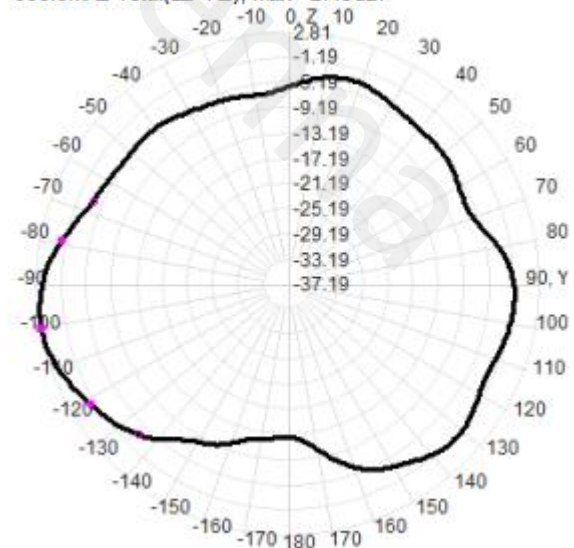

960.0MHz H+V, Eff: 61.6%

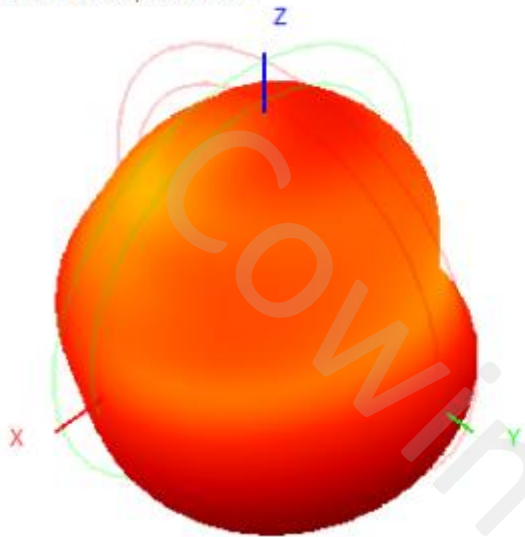

Back View

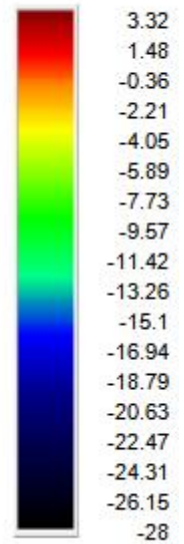
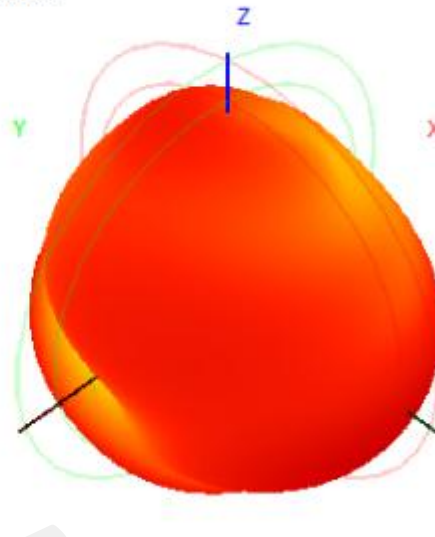

960.0MHz Total(E1-XZ), Max= 1.29dBi

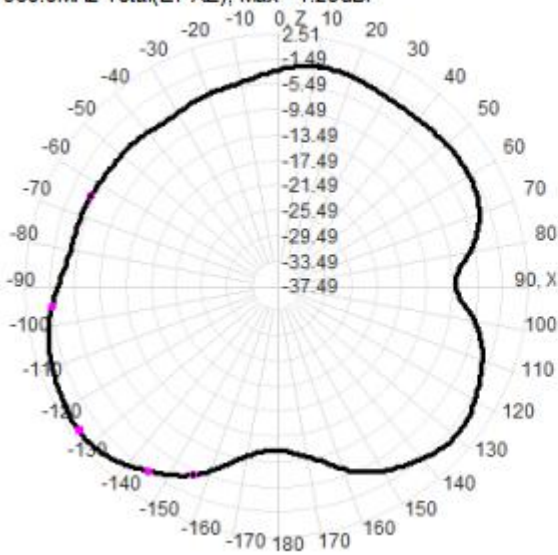

960.0MHz Total(E2-YZ), Max= 2.51dBi

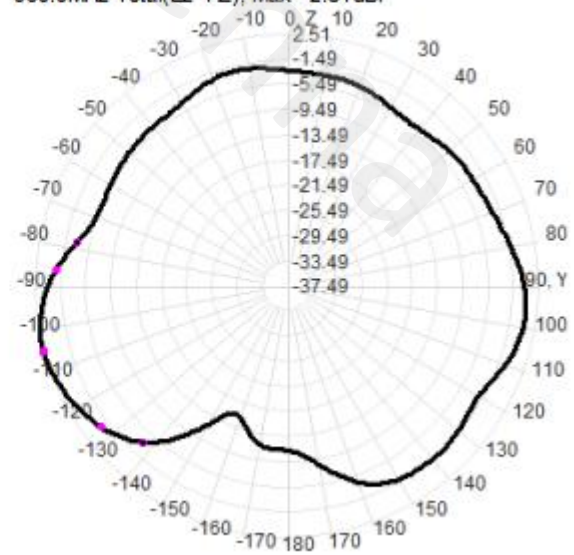

1710.0MHz H+V, Eff: 51.9%

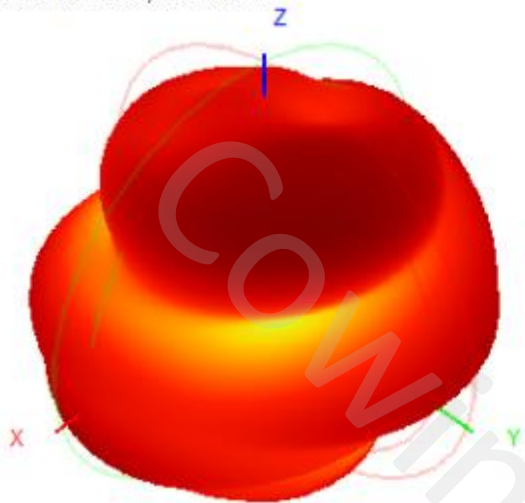

Back View

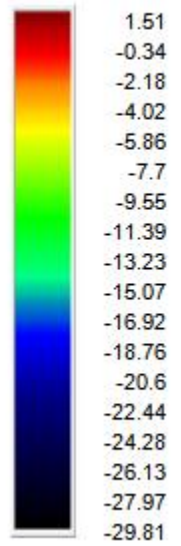
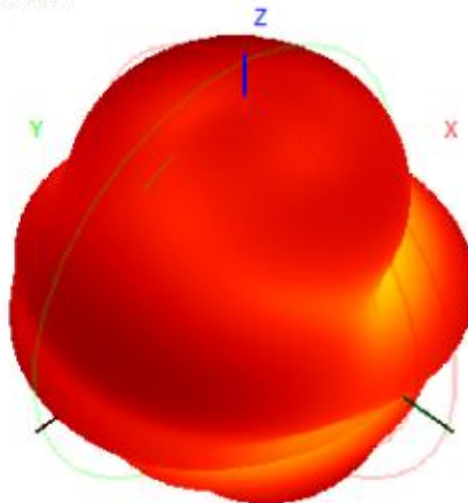

1710.0MHz Total(E1-XZ), Max= 0.49dBi

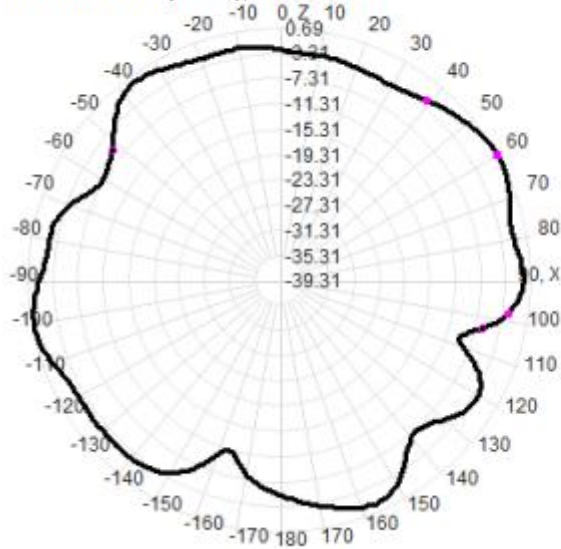

1710.0MHz Total(E2-YZ), Max= 0.69dBi

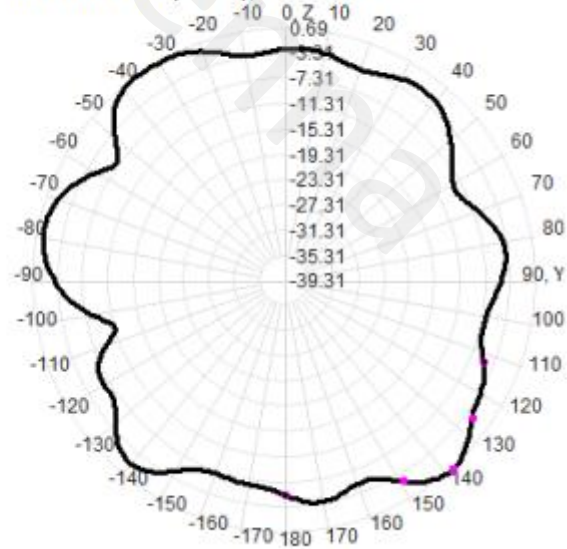

1950.0MHz H+V, Eff: 56.3%

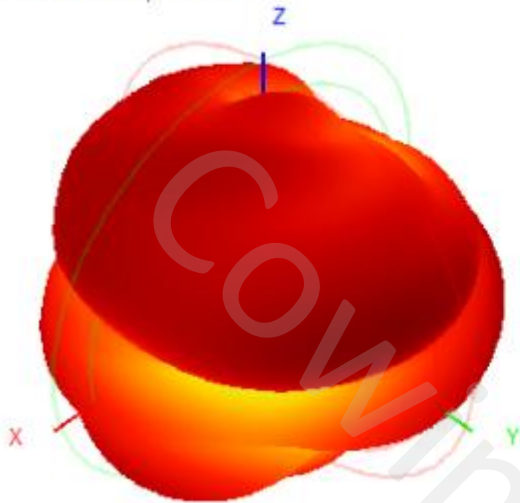

Back View

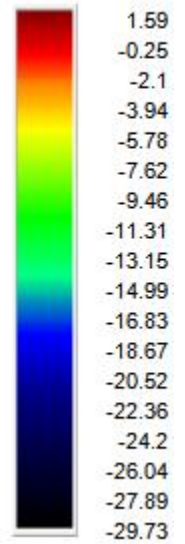
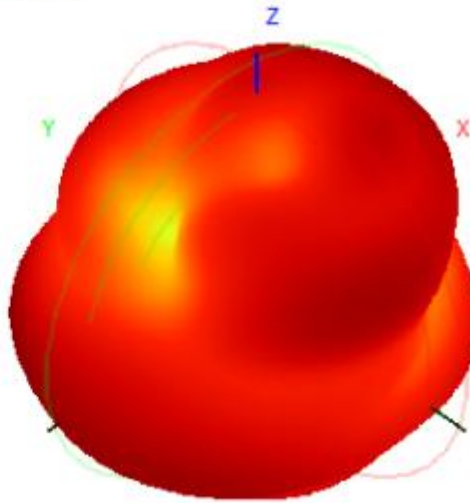

1950.0MHz Total(E1-XZ), Max= 0.79dBi

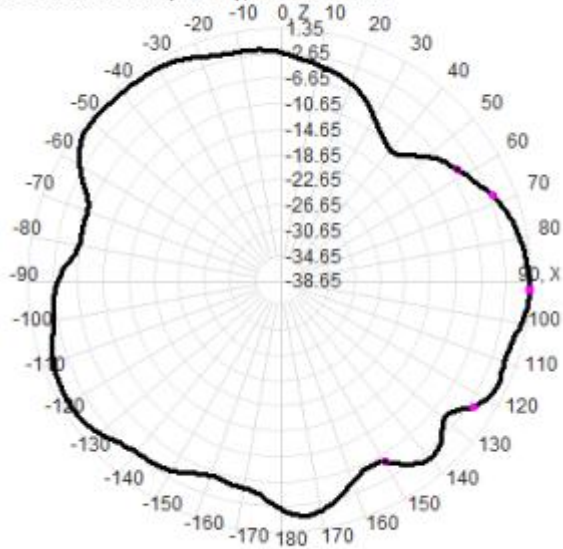

1950.0MHz Total(E2-YZ), Max= 0.94dBi

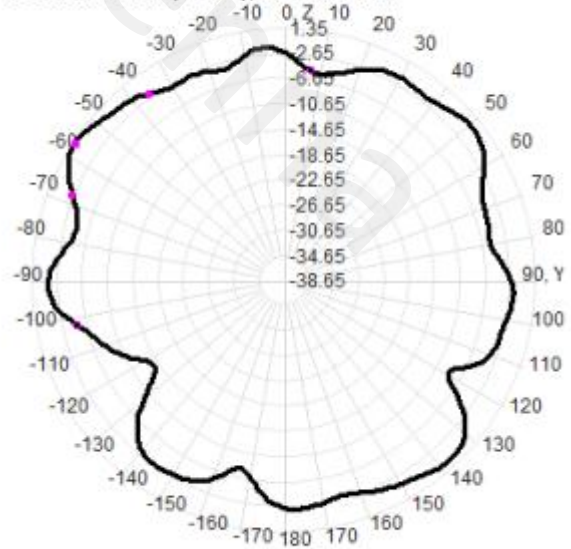

2170.0MHz H+V, Eff: 52.9%

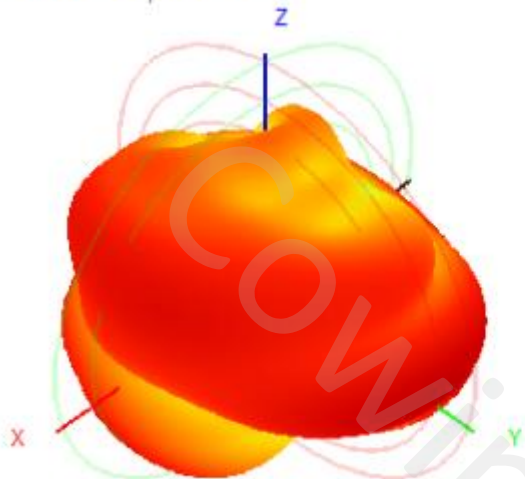

Back View

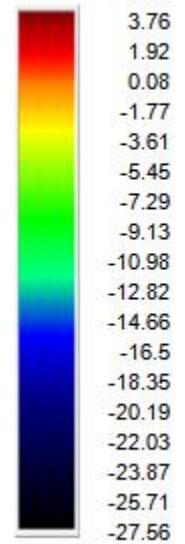
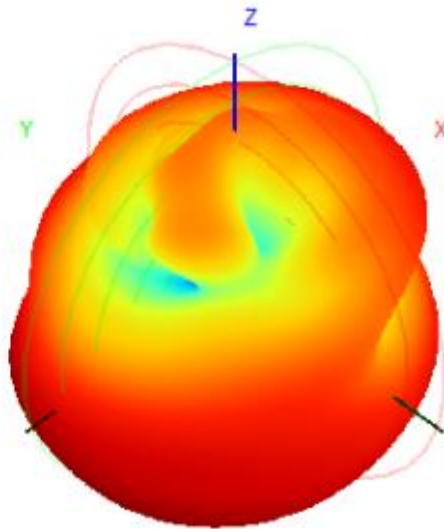

2170.0MHz Total(E1-XZ), Max= 3.35dBi

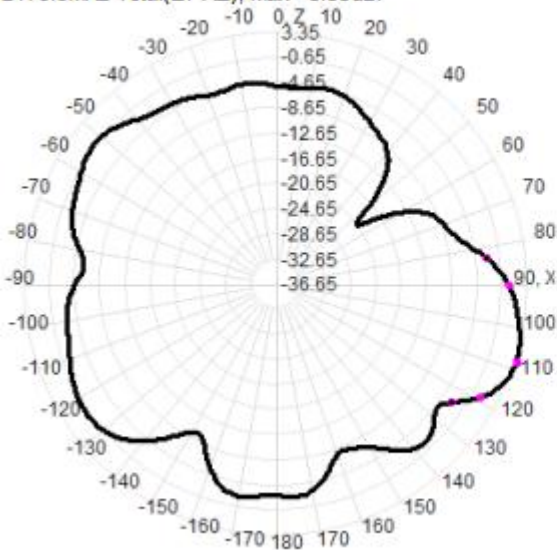

2170.0MHz Total(E2-YZ), Max= 1.33dBi

